

1 | 2 | 3 | 4 | 5 | 6

A

B

C

D

A

B

C

D

REV 更改号	DATE 日期	REVISION DETAILS 更改内容	APPD 审核并批准
①	Jun.2,2017	Delete the thread undercut and change Dim.8.13 to 10.50 and Dim.11.2 to 13.6	
②			

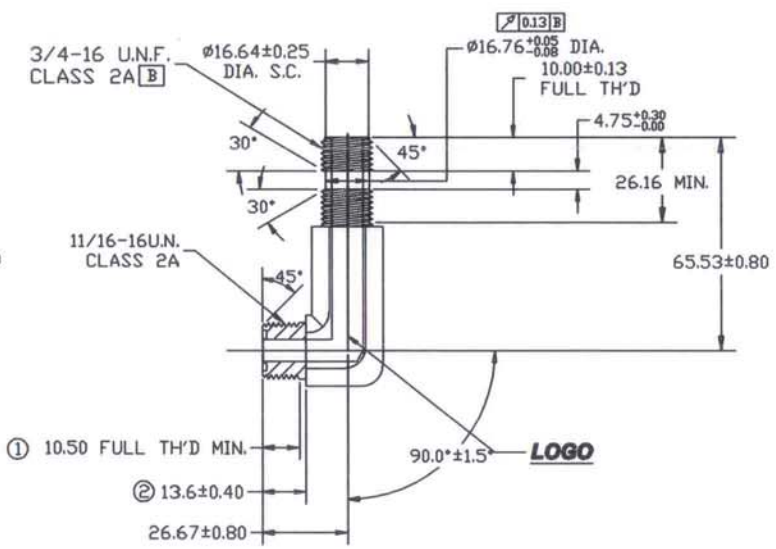
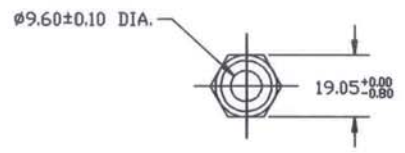
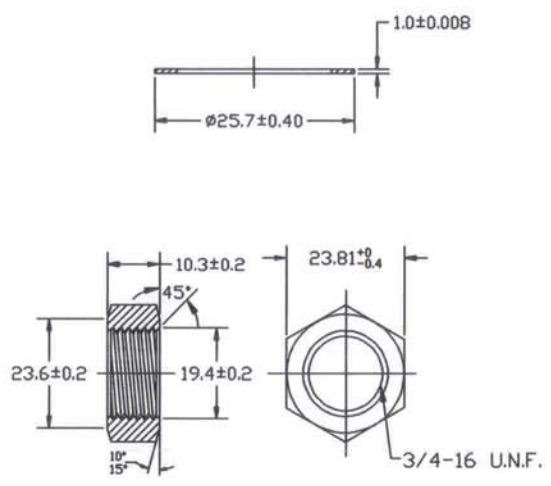

UNLESS SPECIFIED
ALL DIMENSIONS IN mm,
MACHINED SURFACES Ra=3.2um,
ANGLE TOLERANCES ±1°,
Other tolerance except angles,
in accordance with
GB/T1804-2000(ISO2768-1)-m
and GB/T1184-1996(ISO2768-2)-m

其它事项,
图示尺寸单位为mm,
未注机加工表面粗糙度 Ra=3.2um,
未注角度公差 ±1° ,
其它未注公差 (除角度外) 均按:
GB/T1804-2000(ISO2768-1)-m 和
GB/T1184-1996(ISO2768-2)-m

去除所有毛刺, 铁屑等残留物, 锐边倒钝0.127-0.254mm.
镀锌, 三价铬钝化, 银白色, 盐雾试验96小时无白斑.
144小时无红斑, 镀锌层厚度大于12um

Yuhuan Getal Machinery Co., Ltd		
PART No 零件名	FS6801-L-06-08-NW□	
SCALE:	APPD: 批准 Zhang	DRN: 制图 Sun Jiahuan 2017.06.23
NTS	DATE: 日期 2017.06.23	CHK: 审核 LI JunBao 2017.06.23

MATERIAL	Chinese steel 45
FINISH	Remove all sharp edges,burrs,silvers and swarf, break all edges 0.127-0.254mm. ZINC PCATING WITH 12um MICRONS MINIMUM PLATING THICKNESS AND TRIVALENT CHROMATE PASSIVATION AND WITHSTAND 96 HRS TO WHITE/144 HS TO RED RUST IN SALT SPRAY TEST.

1 | 2 | 3 | 4 | 5 | 6

FNAME

REVDATE

USER